

KEY FEATURES

- It incorporates a curvilinear cone attached to a rubber surround, in order to provide suspension stability and to allow maximum excursion linearity with high sensitivity and extremely low distortion.
- It has been specifically designed to deliver exceptional low and mid frequency reproduction.



TECHNICAL SPECIFICATIONS

Nominal diameter	200 mm. 8 in.
Rated impedance	8 ohms
Minimum impedance	6.8 ohms
Power capacity*	50 w RMS
Program power	100 w
Sensitivity	90 dB 2.83v @ 1m @ 2π
Frequency range	35 - 6000 Hz
Recom. enclosure vol.	20 / 60 l 0.7 / 2.12 ft. ³
Voice coil diameter	25.8 mm. 1 in.
Magnetic assembly weight	1 kg. 2.2 lb.
BL factor	6.9 N / A
Moving mass	0.025 kg.
Voice coil length	16 mm
Air gap height	6 mm
X damage (peak to peak)	20 mm

DIMENSION DRAWINGS

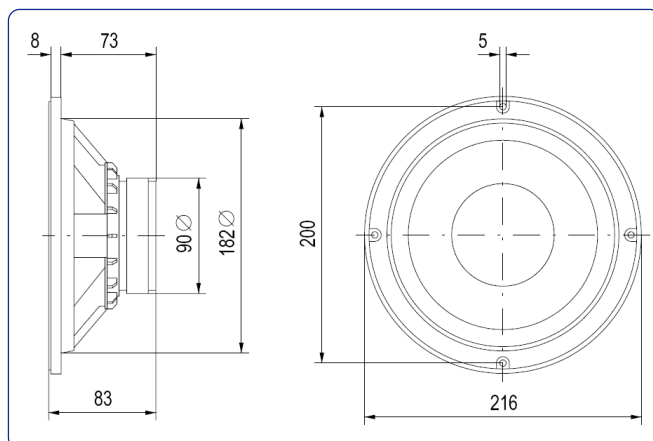

THIELE-SMALL PARAMETERS**

Resonant frequency, fs	33.2 Hz
D.C. Voice coil resistance, Re	6.5 ohms
Mechanical Quality Factor, Qms	2.61
Electrical Quality Factor, Qes	0.73
Total Quality Factor, Qts	0.57
Equivalent Air Volume to Cms, Vas	61.35 l
Mechanical Compliance, Cms	907.7 μm / N
Mechanical Resistance, Rms	2.02 kg / s
Efficiency, ηo (%)	0.3
Effective Surface Area, Sd (m ²)	0.022 m ²
Maximum Displacement, Xmax***	6 mm
Displacement Volume, Vd	130 cm ³
Voice Coil Inductance, Le @ 1 kHz	0.8 mH

MOUNTING INFORMATION

Overall diameter	216 mm. 8.50 in.
Bolt circle diameter	200 mm. 7.87 in.
Baffle cutout diameter:	
- Front mount	182 mm. 7.16 in.
- Rear mount	185 mm. 7.28 in.
Depth	83 mm. 3.26 in.
Volume displaced by driver	1.5 l. 0.05 ft. ³
Net weight	1.36 kg. 2.99 lb.
Shipping weight	1.55 kg. 3.41 lb.

Notes:

*The power capacity is determined according to AES2-1984 (r2003) standard. Program power is defined as the transducer's ability to handle normal music program material.

**T-S parameters are measured after an exercise period using a preconditioning power test. The measurements are carried out with a velocity-current laser transducer and will reflect the long term parameters (once the loudspeaker has been working for a short period of time).

***The Xmax is calculated as (Lvc - Hag)/2 + Hag/3.5, where Lvc is the voice coil length and Hag is the air gap height.

FREE AIR IMPEDANCE CURVE

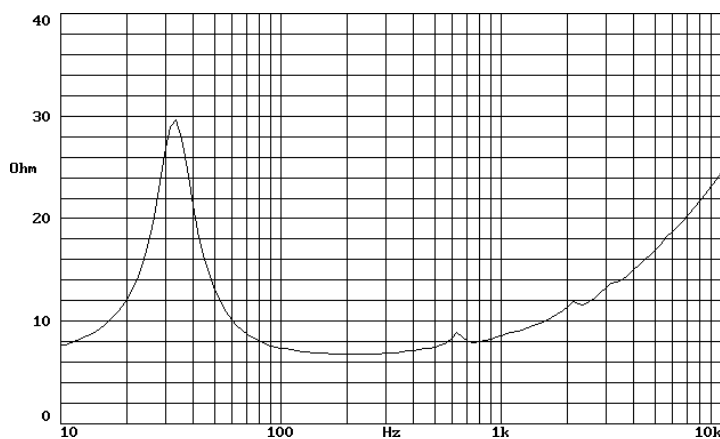

FREQUENCY RESPONSE AND DISTORTION

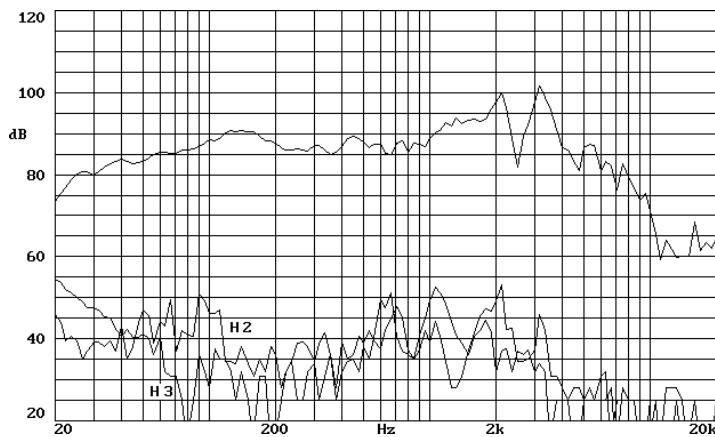

Note: on axis frequency response measured with loudspeaker standing on infinite baffle in anechoic chamber, 1w @ 1m.