

KEY FEATURES

- Exceptional power handling: 200 w AES
- Compact neodymium magnet system
- 3" (77 mm) edgewound aluminium ribbon voice coil
- High efficiency: 8.8%
- Low weight (3.7 kg)
- Extended frequency response with low distortion and excellent linearity
- Designed for the mid-frequencies reproduction



GENERAL DESCRIPTION

This 10" mid bass frequency loudspeaker features a compact, powerful neodymium magnet system, providing exceptional energy level and reducing the total loudspeaker mass. This results in exceptional high efficiency (8.8%), low distortion and excellent linearity, with extended response.

FREQUENCY RESPONSE AND DISTORTION CURVES

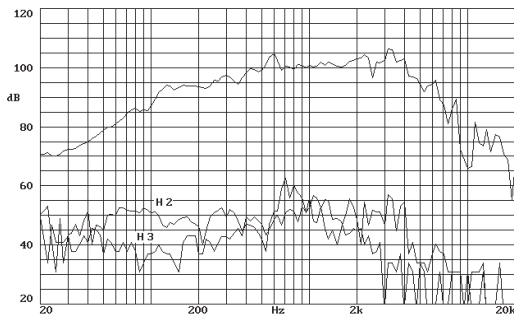

Note: on axis frequency response measured with loudspeaker standing on infinite baffle in anechoic chamber, 1w @ 1m.

FREE AIR IMPEDANCE CURVE

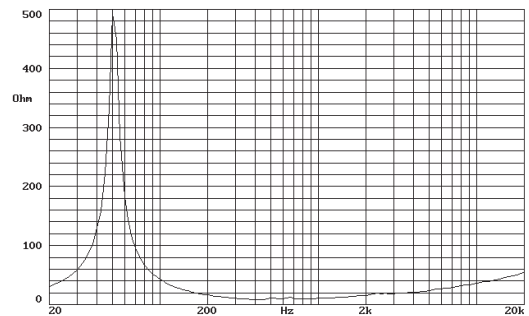

PREDICTED LOW FREQUENCY RESPONSE

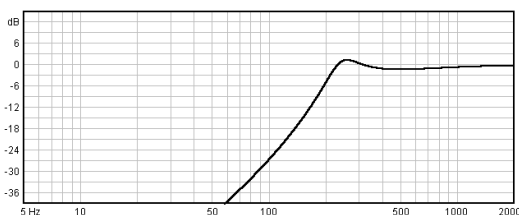

Note: Bass-reflex cabinet, Vb=20 l, fb=240 Hz

POWER COMPRESSION LOSSES

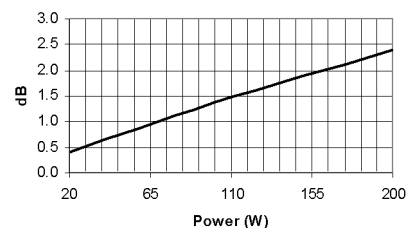

Note: These losses are calculated from a five minutes AES power test applying band limited pink noise (100-5000 Hz). The loudspeaker is free-air standing.

TECHNICAL SPECIFICATIONS

Nominal diameter	250 mm. 10 in.
Rated impedance	8 ohms.
Minimum impedance	8 ohms.
Power capacity*	200 w AES
Program Power	400 w
Sensitivity	103 dB 2.83v @ 1m @ 2π
Frequency range	80 – 6000 Hz
Recom. enclosure vol.	20 / 50 l 0.7 / 1.75 ft ³
Voice coil diameter	77 mm. 3 in.
Magnetic assembly weight	3 kg. 6.6 lb.
BL factor	25.4 N/A
Moving mass	0.033 kg.
Voice coil length	12 mm.
Air gap height	11 mm.
X damage (peak to peak)	16 mm.

MOUNTING INFORMATION

Overall diameter	260.5 mm. 10.25 in.
Bolt circle diameter	243.5 mm. 9.6 in.
Baffle cutout diameter:	
-Front mount	228 mm. 9 in.
-Rear mount	228 mm. 9 in.
Depth	111 mm. 4.4 in.
Volume displaced by driver	2 l 0.07 ft ³
Net weight	3.8 kg. 8.36 lb.
Shipping weight	4.1 kg. 9.02 lb.

THIELE-SMALL PARAMETERS**

Resonant Frequency, fs	53 Hz
D.C. Voice Coil Resistance, Re	5.5 ohms.
Mechanical Quality Factor, Qms	10.1
Electrical Quality Factor, Qes	0.09
Total Quality Factor, Qts	0.09
Equivalent Air Volume to Cms, Vas	56 l
Mechanical Compliance, Cms	273 μm/N
Mechanical Resistance, Rms	1.1 kg/s
Efficiency, ηo (%)	8.8
Effective Surface Area, Sd (m ²)	0.038 m ²
Maximum Displacement, Xmax	2 mm.
Displacement Volume, Vd	106 cm ³
Voice Coil Inductance, Le @ 1kHz	1.5 mH

DIMENSION DRAWINGS

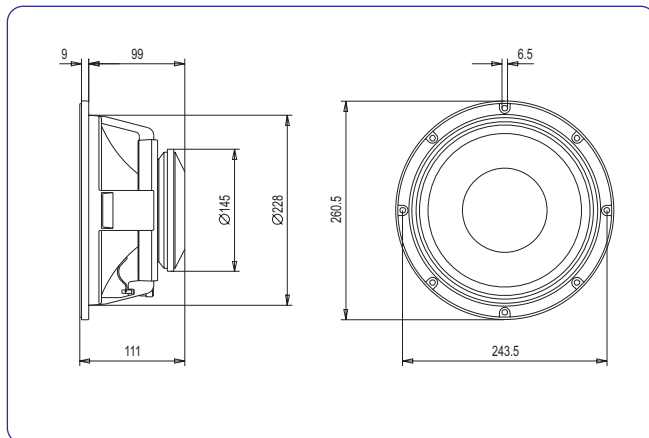

MATERIALS

- **Basket:** Cast aluminium
- **Cone:** Paper
- **Surround:** Treated cloth
- **Voice coil:** Edgewound aluminium ribbon
- **Magnet:** Neodymium

Notes:

* The power capacity is determined according to AES2-1984 (r2003) standard. Program power is defined as the transducer's ability to handle normal music program material.

** T-S parameters are measured after an exercise period using a preconditioning power test. The measurements are carried out with a velocity-current laser transducer and will reflect the long term parameters (once the loudspeaker has been working for a short period of time).



acústica beyma, s.a.